

FinCoater

Light lubricant coating for fin presses

LSP[®] INDUSTRIES, INC.
ROCKFORD, IL 61109

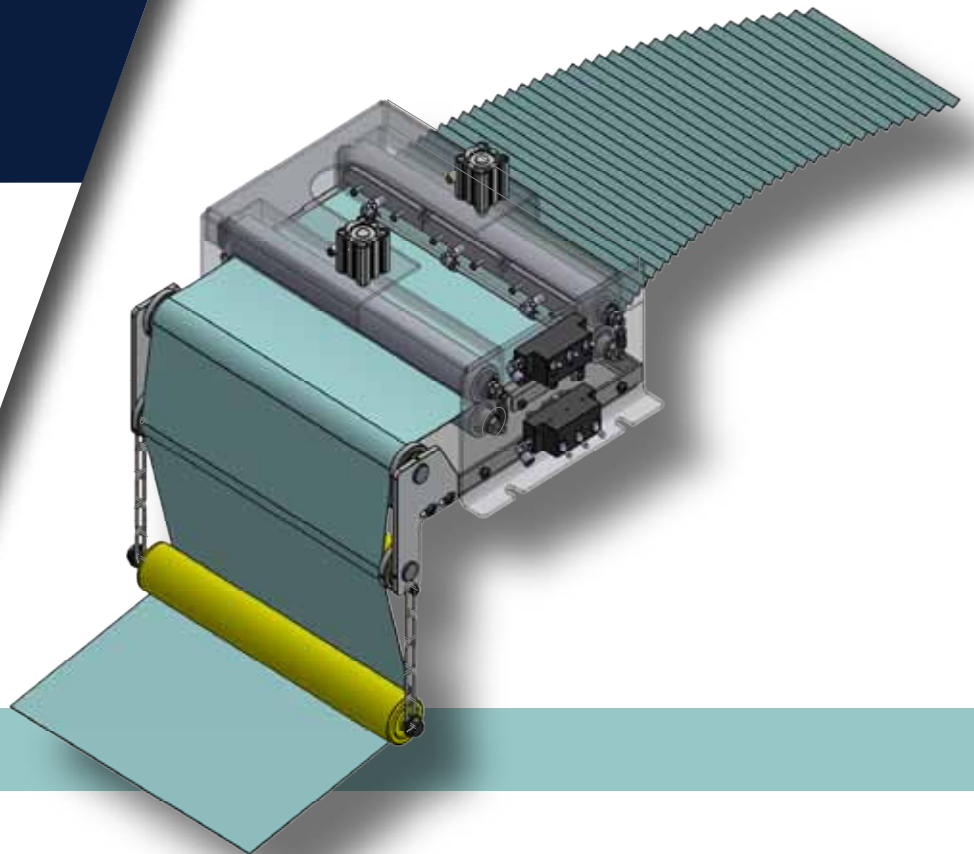

This is How It Works

The ideal roller coater to apply a very light coating of lubricant to thin gage material as it enters the fin press. Computer controlled to dispense the correct amount of lubricant to the material on each stroke of the press. Two sets of rolls, one to take the whip out of the material and one set to apply the lubricant. Shown below are all of the FinCoater features.

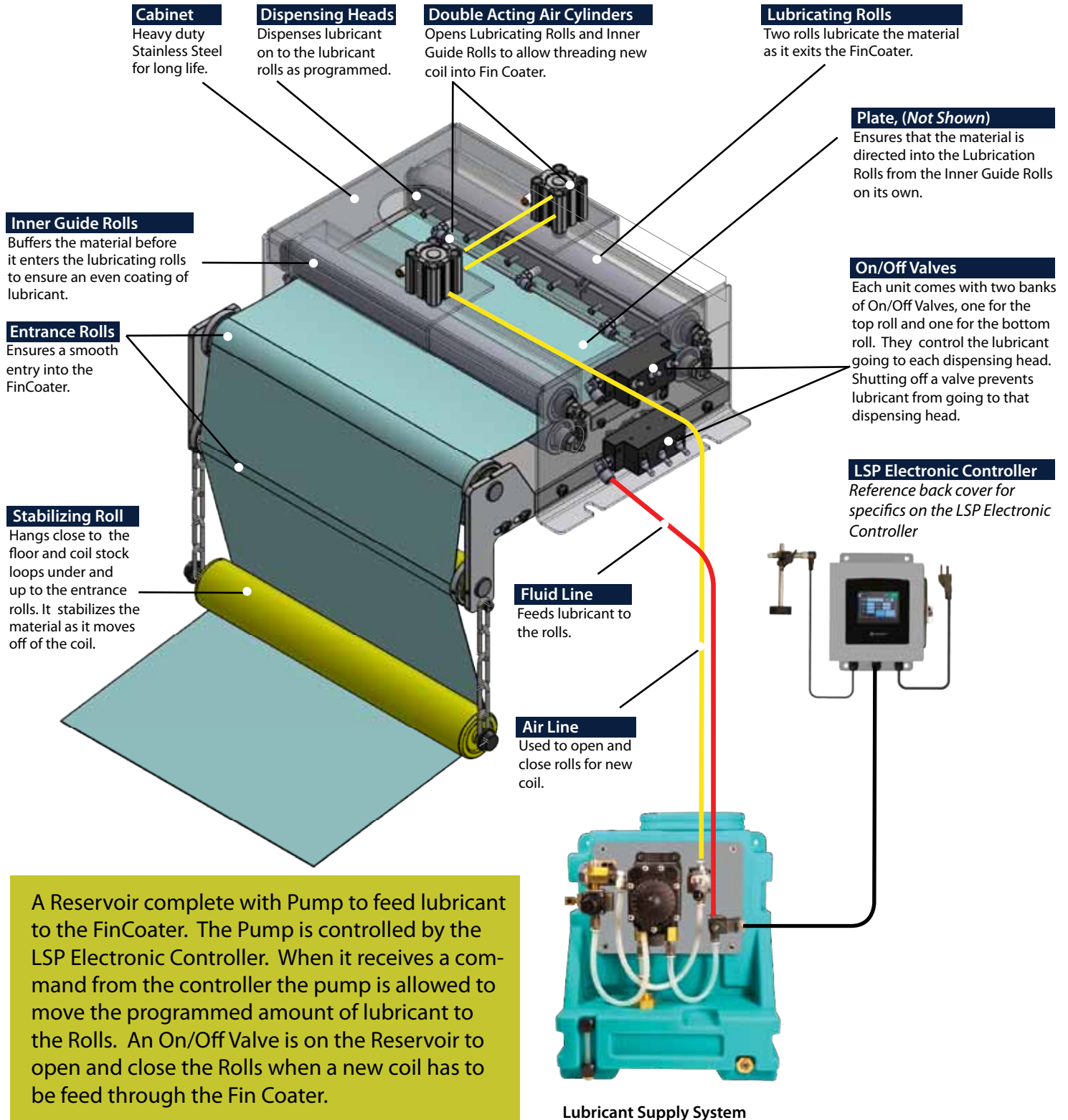

The FinCoater Line

Available with On/Off Manifolds attached to the cabinet or with Remote Manifolds, up to 10 feet away from the cabinet. For larger units the remote can be beneficial in that it eliminates walking around the coil to set the On/Off Valves.

FinCoaters shown below include two Felt Inner Guide Rolls. Lubricating Rolls must be specified and ordered separately.

Basic FinCoater

Includes On/Off Valves ATTACHED to Cabinet, Felt inner Guide Rolls, Entrance Rolls and Stabilizing Roll.

Lubricating Rolls ordered Separately.

- FP8013 - Up to 13" Coil Stock
Three Dispensing Heads per Roll
- FP8019 - Up to 19" Coil Stock
Five Dispensing Heads per Roll
- FP8025 - Up to 25" Coil Stock
Five Dispensing Heads Per Roll
- FP8031 - Up to 31" Coil Stock
Five Dispensing Heads per Roll
- FP8037 - Up to 37" Coil Stock
Seven Dispensing Heads per Roll
- FP8043 - Up to 43" Coil Stock
Seven Dispensing Heads per Roll
- FP8049 - Up to 49" Coil Stock
Seven Dispensing Heads per Roll



Deluxe FinCoater

Includes On/Off Valves REMOTE from the Cabinet, Felt inner Guide Rolls, Entrance Rolls and Stabilizing Roll.

Lubricating Rolls ordered Separately.

- FP8213 - Up to 13" Coil Stock
Three Dispensing Heads per Roll
- FP8219 - Up to 19" Coil Stock
Five Dispensing Heads per Roll
- FP8225 - Up to 25" Coil Stock
Five Dispensing Heads Per Roll
- FP8231 - Up to 31" Coil Stock
Five Dispensing Heads per Roll
- FP8237 - Up to 37" Coil Stock
Seven Dispensing Heads per Roll
- FP8243 - Up to 43" Coil Stock
Seven Dispensing Heads per Roll
- FP8249 - Up to 49" Coil Stock
Seven Dispensing Heads Per Roll

Lubricating Felt Rolls

The Felt Roll are absorbent giving more versatility in the lubricant thickness being applied to the stock. A small amount of lubricant can provide a light almost invisible coating to the stock. Increasing the amount of lubricant will provide a medium or heavier coating.



FinCoater Dimensions

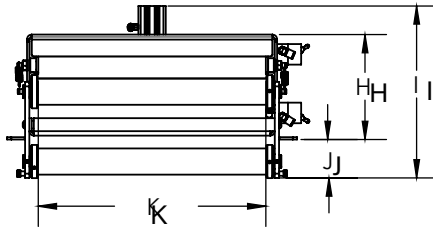
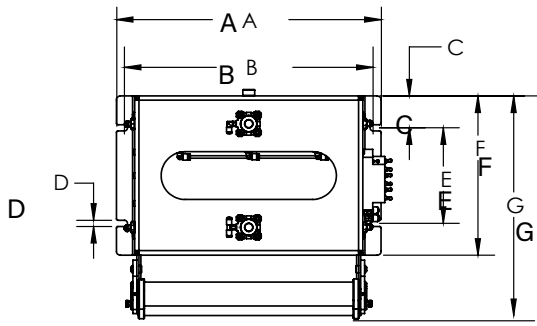

FinCoater	A	B	C	D	E	F	G	H	I	K
FP8013 & FP9213	16.62	15.62	2.00	0.39	6.00	10.00	13.800	9.90	2.20	13.00
FP8019 & FP8219	22.62	21.62	2.00	0.39	6.00	10.00	13.800	9.90	2.20	19.00
FP8025 & FP8225	28.62	27.62	2.00	0.39	6.00	10.00	13.800	9.90	2.20	25.00
FP8031 & FP8231	34.62	33.62	3.00	0.39	6.00	12.00	16.525	12.30	2.20	35.00
FP8037 & FP8237	40.62	39.62	3.00	0.39	6.00	12.00	16.525	12.30	2.20	37.00
FP8043 & FP8243	46.79	45.79	3.00	0.39	6.00	12.00	16.525	12.30	2.20	43.00
FP8049 & FP8249	52.62	51.62	3.00	0.39	6.00	12.00	16.525	12.30	2.20	49.00



FC-4000 & FC-4002
One Output & Two Outputs

LSP Controller: Regulates when lubricant is dispensed and how much is dispensed.

Includes:

Proximity Sensor: Senses when an object passes by it and sends signal to the Controller

Touch Screen: Visually set program parameters.

Lockout: Prevents unauthorized personnel from changing the program.

Time Delay: Determines how long a delay will transpire before activating the Diaphragm Pump after a signal is received.

Pulsator: Gives the Pump multiple actuations per cycle of the press.

Counter: Allows the Pump to actuate on cycle of the press from 1 - 99.

Memory: Memory functions allows user save up to 99 jobs and recall settings when job is run again.



Reservoir with Pump
and On/Off Valve

Reservoir & Pump Modules

FP7324 Four Gallon Reservoir

FP7328 Eight Gallon Reservoir

FP7330 Fifteen Gallon Reservoir

Pump: Pumps lubricant to the FinCoater when the Solenoid Valve is activated.

Solenoid Valve: Will open when it receives a command from the LSP Electronic Controller.

Air Valve: Used to Open/Close the Lubricating Rolls and the Inner Guide Rolls to allow new coil to be threaded into the FinCoater.

Air Regulator: Adjust the air pressure to the pump to regulate the pressure that the lubricant is fed to the Lubricating Rolls.



P.O. Box 5303, 61125 • 5060 - 27TH AVE., • Rockford, IL. 61109

TEL: 815-226-8090 • FAX: 815-226-9250 • E-MAIL: SALES@LSPIND.COM • WEB: WWW.LSPIND.COM