

REPLACEMENT PARTS LISTING

MAIN PARTS LIST (reference Figure #3) for the MicroSpray Reservoir Module P-708-A

Key Part No.	No. Pcs	Description -or- Part Name	Key Part No.	No. Pcs	Description -or- Part Name
1	RES029	1 RESERVOIR, Tank:	16	FIT072	2 FITTING, Support: tube
2	COV004	1 COVER, Tank:	17	TUB225	1 TUBE, Plastic:
3	NUT058	2 NUT, Hexagon: jam	18	FIT071	1 FITTING, Adapter:
4	RGO030	2 RING, "O" type: seal	19	RGO017	3 RING, "O" type: seal
5	INL026	1 INLET, Sight Glass:	20	BRK026	3 BRACKET, Mounting:
6	RGO013	2 RING, "O" type: seal	21	NUT104	3 NUT, Hexagon: locking
7	PIP007	1 PIPE, Plastic: sight	**A 200BD11	1	MicroSpray Module
8	OUT009	1 OUTLET, Sight Glass:			
9	RGO034	1 RING, "O" type: seal			
10	PLG026	1 PLUG, Sight Glass:			
11	FIL011	1 FILTER, Wire:			
12	ADP064	1 ADAPTER, Filter:			
13	RGO014	1 RING, "O" type: seal			
14	OUT008	1 OUTLET, Fluid:			
15	FIT069	1 FITTING, Elbow:			

** See MAIN PARTS LIST for the MicroSpray Module for further breakdown of parts.

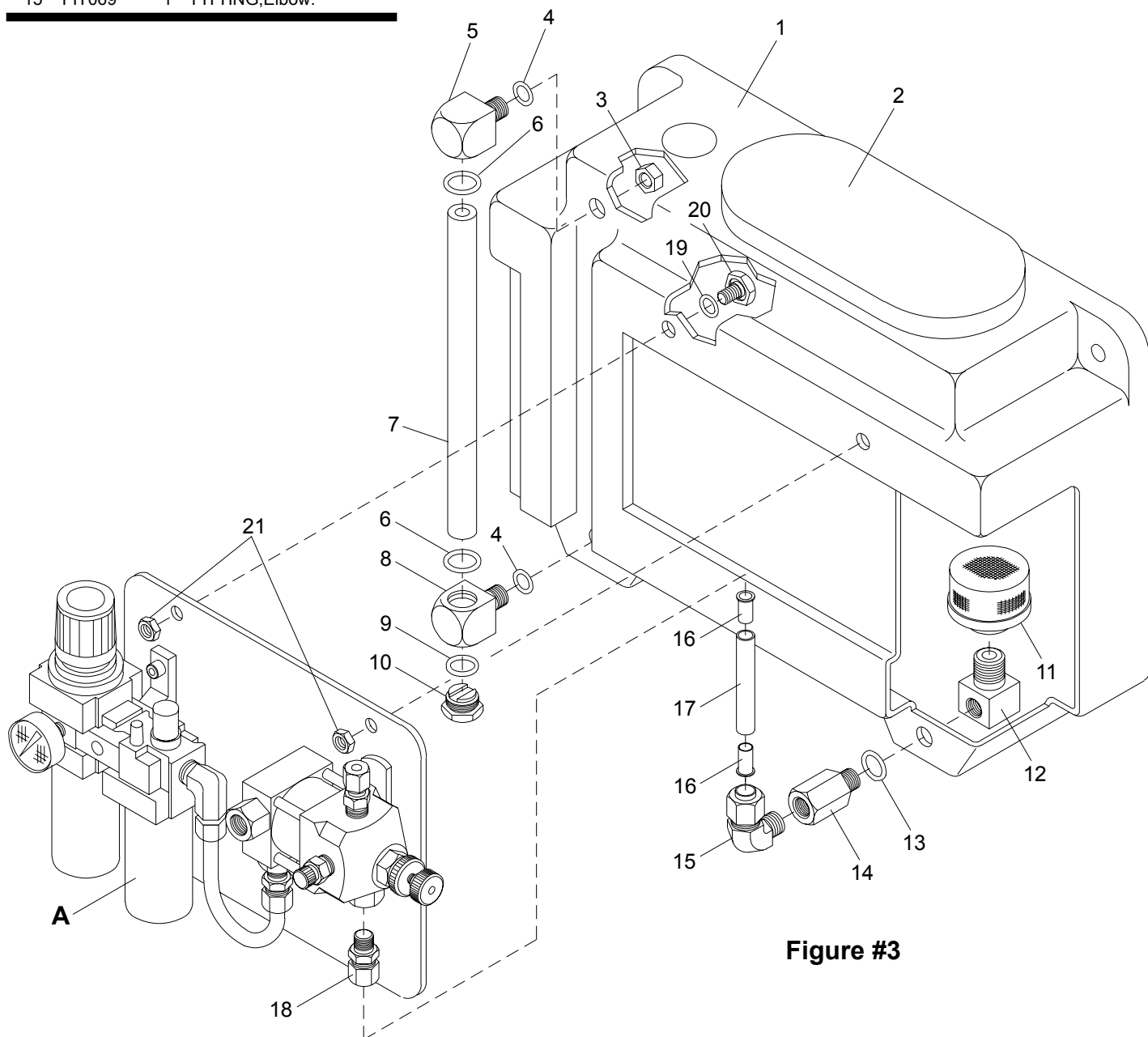

Figure #3

INSTALLATION, OPERATION, and TROUBLESHOOTING

with REPLACEMENT PARTS LISTING for the
MicroSpray Module Models **P-700-A & P-708-A**
Supercedes MicroSpray Models **P-700 & P-708**



P.O. Box 5303, ROCKFORD, IL • 61125
2511-20TH ST., ROCKFORD, IL • 61104
TEL: 815-226-8090 • FAX: 815-226-9250
E-MAIL: SALES@LSPIND.COM

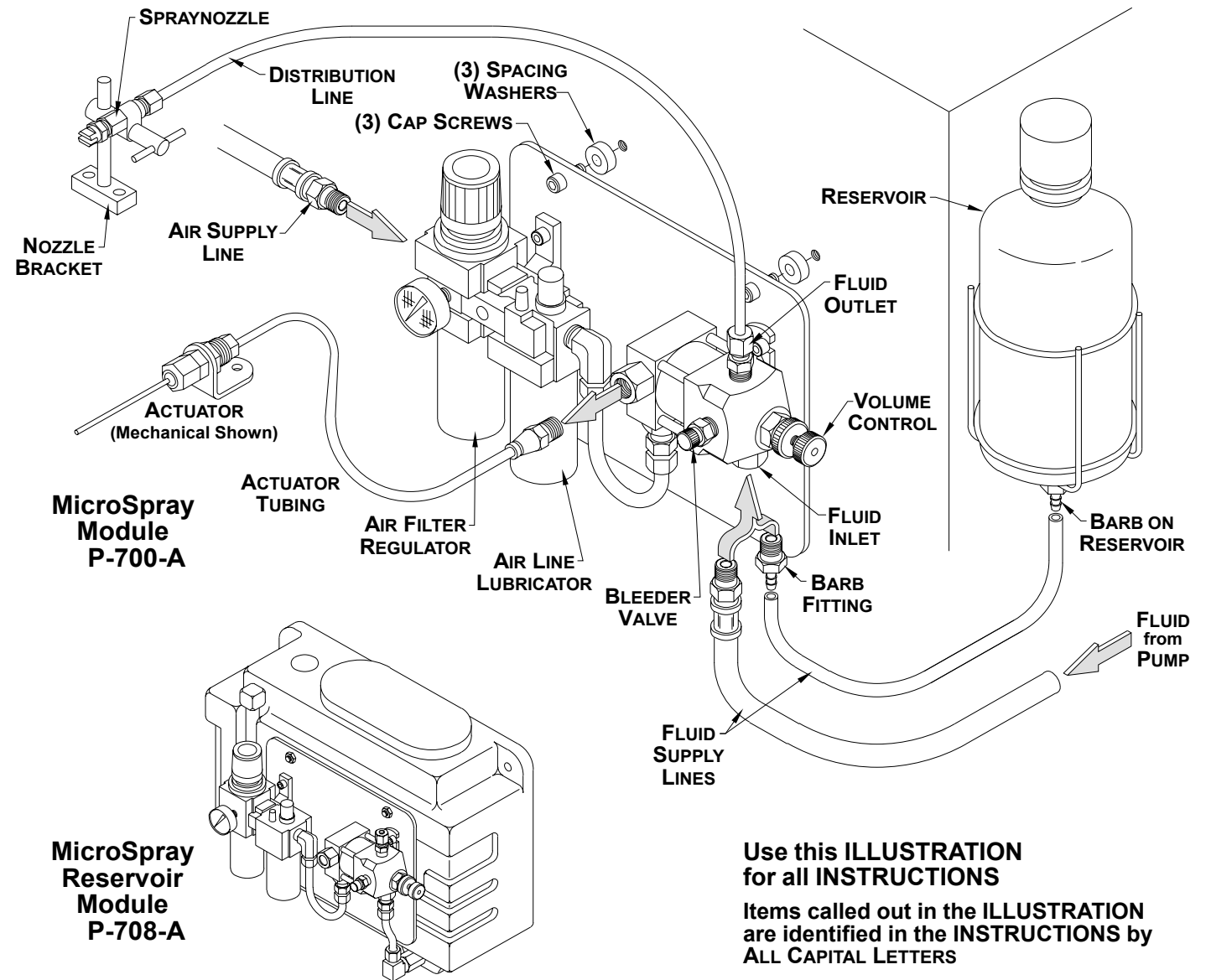

Use this ILLUSTRATION for all INSTRUCTIONS

Items called out in the ILLUSTRATION are identified in the INSTRUCTIONS by ALL CAPITAL LETTERS

The term UNIT is used to designate the entire MicroSpray Module

SUPPLEMENTAL INSTRUCTIONS

These INSTRUCTIONS rely heavily on information found in supplemental Instruction Sheets. Before starting, make sure that the **INSTALLATION, OPERATION & TROUBLESHOOTING** Instructions with the following subtitles are available for reference.

- **for the MicroSpray__ Model No. P-010-A**
Describes the operation and maintenance of the MicroSpray. The MicroSpray provides the lubricant spraying function.
- **for the (appropriate ACTUATOR chosen)**
Describes the device chosen to actuate the UNIT. There are a variety of these. You must have one to operate the UNIT, and along with it, must have its Instruction Sheet.

If any Instruction Sheet above is missing, locate it. If not found, request a replacement from L.S.P.

These Instruction Sheets are absolutely necessary for proper installation and maintenance of the UNIT, always keep them attached to these Instructions.

NOTE:

These Instructions cover two different Model Units. Most of the data herein pertains to both; however, should a paragraph only pertain to a specific Model, that paragraph will begin "Only for Model No...." and give the respective Model Number for that UNIT.

INSTALLATION INSTRUCTIONS

A. Installing the Actuator

See the Instruction Sheet for the **ACTUATOR** you have chosen to use. Follow the given **INSTALLATION INSTRUCTION** for that **ACTUATOR**.

If you have no **ACTUATOR**, see the **ACCESSORIES** Section of the **MicroSpray** Instruction Sheet for a list of those available.

B. Installing the UNIT

See the **MicroSpray's** Instruction Sheet under the heading **Installing the MicroSpray**.

1. Locating the UNIT

Consider the suggestions given for the **MicroSpray** under the similar heading. The same applies for this **UNIT**.

2. Mounting the UNIT

Only for Model No. P700-A. Drill and tap for three 1/4-20 screws on center with the holes in the **MOUNTING PLATE**.

Use the **SPACING WASHERS** supplied to keep the **PLATE** away from the mounting surface (done to relieve for protrusions on the back side of the **PLATE**).

Insert screws through the holes and washers, and torque securely into the tapped holes.

Only for Model No. P708-A. This **UNIT** can be simply set into place on the feet provided by the **RESERVOIR**, or it can be mounted on a wall using the holes provided in the tabs of the **RESERVOIR**.

For wall mounting; drill and tap for two 1/4-20 screws on center with holes in **RESERVOIR**. Insert screws and torque.

C. Installing the Fluid Supply

Only for Model No. P700-A. See the **MicroSpray's** Instruction Sheet under the similar heading. Use the appropriate area in the instructions (for using a **RESERVOIR** or **PUMP**).

Only for Model No. P708-A. The **RESERVOIR** is included with this **UNIT**, which is simply filled with the lubricant.

D. Installing Air Supply

See the **MicroSpray's** Instruction Sheet under the same heading. The same principles apply for this **UNIT**.

The **AIR FILTER/REGULATOR/LUBRICATOR** which is recommended in the Instruction is included with this **UNIT**. The **AIR SUPPLY** is to be connected at it's **AIR INLET PORT** as illustrated.

E. Installing the Distribution System

See the **MicroSpray's** Instruction Sheet under the same heading. The same principles apply for this **UNIT**.

OPERATING INSTRUCTIONS

All operation concerning the spraying of the lubricant is the same as described in the **MicroSpray's OPERATING INSTRUCTION**. Follow the instructions given therein.

All operation concerning the control of the **UNIT** is described in the **OPERATING INSTRUCTIONS** for the chosen **ACTUATOR**. Follow the instructions given therein.

TROUBLESHOOTING

See the appropriate **TROUBLESHOOTING INSTRUCTIONS** for the **MicroSpray** or **ACTUATOR** depending on the type of problem to be solved.

Use the **REPLACEMENT PARTS LISTING** at the left and at back for parts not found in the other **INSTRUCTIONS**.

REPLACEMENT PARTS LISTING

MAIN PARTS LIST (reference Figure #1)

for the MicroSpray Module P-700-A

Key Part No.	No. Number	No. Pcs	Description -or- Part Name
1	PLT060	1	PLATE,Mounting:
2	WAS015	4	WASHER,Plain:
3	SCR074	2	SCREW,Cap:
4	FIT071	1	FITTING,Adapter:
5	TUB301	1	TUBE,Copper:
6	FIT070	1	FITTING,Elbow:
7	SCR007	2	SCREW,Cap:
8	SPC016	3	SPACER,Washer:
9	SCR011	3	SCREW,Cap:
10	FIT018	1	FITTING,Nut:
11	TUB063	1	TUBE,Copper:
A	210EJT01	1	MicroSpray Model P-010-A
B	REG006	1	Air Regulator/Oiler

Supplemental Parts Listings

The Parts below are further broken down in Supplemental Parts Listings and Illustrations.

Key Part No.	Description	Listing References
A	MicroSpray	See Instruction Sheet for the MicroSpray Model P-010-A
B	Air Handling	See the Parts Listing "B" & Figure #2

Figure #1

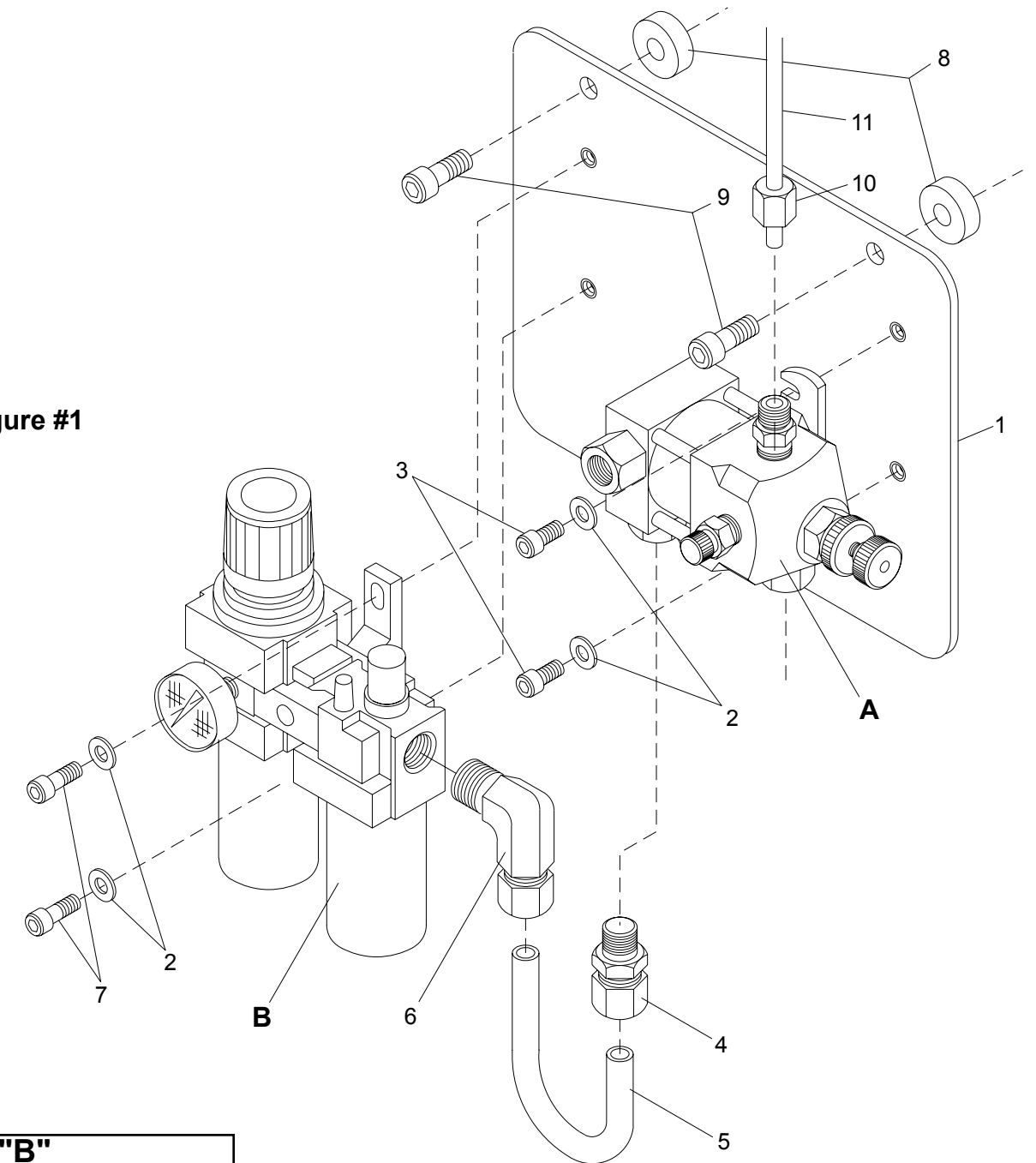
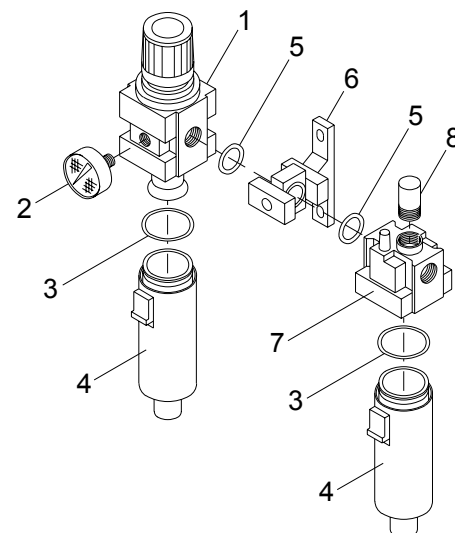

Figure #2



PART LIST "B" Air Handling (reference Fig #2)

REG-016 Includes all except GAU-001

Key Part No.	No. Number	No. Pcs	Description -or- Part Name
1	ACY-028	1	REGULATOR, Bonnet:
2	GAU-001	1	GAUGE, Pressure:
3	RGO-074	2	"O" RING, Seal:
4	ACY-026	2	BOWL, Filter/Oiler:
5	RGO-067	2	"O" RING, Seal:
6	ACY-030	1	BRACKET, Filter/Oiler:
7	ACY-029	1	OILER, Bonnet:
8	ACY-022	1	DOME, Sight: